

ISO 29301:2010

Annulé le / Withdrawn on 2017-12-01

JUIN 2010

www.afnor.org

Ce document est à usage exclusif et non collectif des clients AFNOR.
Toute mise en réseau, reproduction et rediffusion, sous quelque forme que ce soit, même partielle, sont strictement interdites.

This document is intended for the exclusive and non collective use of AFNOR customers.
All network exploitation, reproduction and re-dissemination, even partial, whatever the form (hardcopy or other media), is strictly prohibited.



**DOCUMENT PROTÉGÉ
PAR LE DROIT D'AUTEUR**

Droits de reproduction réservés. Sauf prescription différente, aucune partie de cette publication ne peut être reproduite ni utilisée sous quelque forme que ce soit et par aucun procédé, électronique ou mécanique, y compris la photocopie et les microfilms, sans accord formel.

Contacteur :
AFNOR – Norm'Info
11, rue Francis de Pressensé
93571 La Plaine Saint-Denis Cedex
Tél : 01 41 62 76 44
Fax : 01 49 17 92 02
E-mail : norminfo@afnor.org

AFNOR

Pour : GN-MEBA

Client : 23432617

le : 05/03/2018 à 13:55

Diffusé avec l'autorisation de l'éditeur

Distributed under licence of the publisher

afnor

INTERNATIONAL STANDARD

ISO 29301

First edition
2010-06-01

Microbeam analysis — Analytical transmission electron microscopy — Methods for calibrating image magnification by using reference materials having periodic structures

*Analyse par microfaisceaux — Microscopie électronique en
transmission analytique — Méthodes d'étalonnage du grandissement
d'image au moyen de matériaux de référence de structures périodiques*



Reference number
ISO 29301:2010(E)

© ISO 2010

ISO 29301:2010(E)

PDF disclaimer

This PDF file may contain embedded typefaces. In accordance with Adobe's licensing policy, this file may be printed or viewed but shall not be edited unless the typefaces which are embedded are licensed to and installed on the computer performing the editing. In downloading this file, parties accept therein the responsibility of not infringing Adobe's licensing policy. The ISO Central Secretariat accepts no liability in this area.

Adobe is a trademark of Adobe Systems Incorporated.

Details of the software products used to create this PDF file can be found in the General Info relative to the file; the PDF-creation parameters were optimized for printing. Every care has been taken to ensure that the file is suitable for use by ISO member bodies. In the unlikely event that a problem relating to it is found, please inform the Central Secretariat at the address given below.



COPYRIGHT PROTECTED DOCUMENT

© ISO 2010

All rights reserved. Unless otherwise specified, no part of this publication may be reproduced or utilized in any form or by any means, electronic or mechanical, including photocopying and microfilm, without permission in writing from either ISO at the address below or ISO's member body in the country of the requester.

ISO copyright office
Case postale 56 • CH-1211 Geneva 20
Tel. + 41 22 749 01 11
Fax + 41 22 749 09 47
E-mail copyright@iso.org
Web www.iso.org

Published in Switzerland

Contents

Page

Foreword	iv
Introduction	v
1 Scope	1
2 Normative references	1
3 Terms, definitions and abbreviated terms	1
4 Image magnification	5
4.1 Definition of the image magnification	5
4.2 Expressing magnification	6
5 Reference materials	7
5.1 General	7
5.2 Requirements for CRM/RM	7
5.3 Storage and handling	7
6 Calibration procedures	7
6.1 General	7
6.2 Mounting CRM/RM	8
6.3 Setting TEM operating conditions for calibration	8
6.4 Capturing digitized image	10
6.5 Digitizing the image recorded on photographic film	11
6.6 Measurement of the angle-corrected distance D_t from the digitized image	12
6.7 Digitization of reference scale for pixel size calibration	15
6.8 Calibration of image magnification	16
6.9 Calibration of scale bar	18
6.10 Calibration procedure for length measurements using photographic film only	19
7 Accuracy of image magnification	19
8 Uncertainty of measurement result	20
9 Calibration report	21
9.1 General	21
9.2 Contents of calibration report	22
Annex A (informative) Parameters that influence the resultant magnification of a TEM	23
Annex B (normative) Flowchart of image-magnification calibration procedure	24
Annex C (normative) How to decide the number of lines for averaging	25
Annex D (informative) Reference materials for magnification calibration	28
Annex E (informative) Example of test report for calibration of TEM magnification	31
Bibliography	40

ISO 29301:2010(E)

Foreword

ISO (the International Organization for Standardization) is a worldwide federation of national standards bodies (ISO member bodies). The work of preparing International Standards is normally carried out through ISO technical committees. Each member body interested in a subject for which a technical committee has been established has the right to be represented on that committee. International organizations, governmental and non-governmental, in liaison with ISO, also take part in the work. ISO collaborates closely with the International Electrotechnical Commission (IEC) on all matters of electrotechnical standardization.

International Standards are drafted in accordance with the rules given in the ISO/IEC Directives, Part 2.

The main task of technical committees is to prepare International Standards. Draft International Standards adopted by the technical committees are circulated to the member bodies for voting. Publication as an International Standard requires approval by at least 75 % of the member bodies casting a vote.

Attention is drawn to the possibility that some of the elements of this document may be the subject of patent rights. ISO shall not be held responsible for identifying any or all such patent rights.

ISO 29301 was prepared by Technical Committee ISO/TC 202, *Microbeam analysis*, Subcommittee SC 3, *Analytical electron microscopy*.

Introduction

The transmission electron microscope is widely used to investigate the micro/nano-structure of a range of important materials such as semiconductors, metals, nano-particles, polymers, ceramics, glass, food and biological materials. This International Standard is relevant to the need for magnification calibration of the images. It describes the requirements for calibration of the image magnification in the transmission electron microscope using a certified reference material or a reference material having periodic structures.

Microbeam analysis — Analytical transmission electron microscopy — Methods for calibrating image magnification by using reference materials having periodic structures

1 Scope

This International Standard specifies a calibration procedure applicable to images recorded over a wide magnification range in a transmission electron microscope (TEM). The reference materials used for calibration possess a periodic structure, such as a diffraction grating replica, a super-lattice structure of semiconductor or an analysing crystal for X-ray analysis, and a crystal lattice image of carbon, gold or silicon. This International Standard is applicable to the magnification of the TEM image recorded on a photographic film, or an imaging plate, or detected by an image sensor built into a digital camera. This International Standard also refers to the calibration of a scale bar. This International Standard does not apply to the dedicated critical dimension measurement TEM (CD-TEM) and the scanning transmission electron microscope (STEM).

2 Normative references

The following referenced documents are indispensable for the application of this document. For dated references, only the edition cited applies. For undated references, the latest edition of the referenced document (including any amendments) applies.

ISO Guide 30:1992, *Terms and definitions used in connection with reference materials*

ISO Guide 34:2000, *General requirements for the competence of reference material producers*

ISO Guide 35:2006, *Reference materials — General and statistical principles for certification*

ISO/IEC 17025:2005, *General requirements for the competence of testing and calibration laboratories*

ISO/IEC Guide 98-3:2008, *Uncertainty of measurement — Part 3: Guide to the expression of uncertainty in measurement (GUM:1995)*

3 Terms, definitions and abbreviated terms

For the purposes of this document, the terms and definitions in ISO Guide 30 and the following apply.

3.1

alignment

series of operations to align the incident direction of the electron beam to the optical axis using deflectors and/or mechanical knobs

3.2

beam damage

specimen damage generated by irradiation with the electron beam

ISO 29301:2010(E)

3.3 certified reference material CRM

reference material, accompanied by a certificate, one or more of whose property values are certified by a procedure which establishes its traceability to an accurate realization of the unit in which the property values are expressed, and for which each certified value is accompanied by an uncertainty at a stated level of confidence

NOTE For the purposes of this International Standard, a CRM possesses periodic structure(s), with the desired range of periodic interval and accuracy, to be used for the calibration of the image magnification.

3.4 contamination

formation of a deposited layer of any material due to the interaction of the electron beam with the sample and/or its immediate environment

3.5 crystal orientation

direction of crystal which is represented by crystal index

NOTE During TEM imaging, it is often useful to have a crystalline specimen aligned such that a specific (low index) zone axis is parallel, or nearly parallel, to the beam direction (optical axis).

3.6 defocus

focusing condition in which the vertical positioning of the specimen is not coincident with the object plane of the objective lens

NOTE Over-focus condition is that the specimen height is nearer the lens than the object plane, under-focus condition is that the specimen height is further from the lens than the object plane.

3.7 diffraction grating replica

shadow-casting carbon replica film constituting a grating which contains 500 to 2 000 parallel grooves per millimetre, or cross-line grating with a similar line spacing

NOTE A diffraction grating replica can be used as a reference material for calibration of the image magnification in the low to medium-low magnification range.

3.8 digital camera

device that detects the image using a chip-arrayed image sensor, such as a charge-coupled device (CCD) or complementary metal-oxide semiconductor (CMOS), that converts a visual image to an electric signal

3.9 dynamic range

range of detectable electron doses illuminated on the detector, in which the image signal can be detected properly

3.10 excitation current

electric current applied to the coil of the magnetic lens

3.11 glass scale

ruler on which a fine scale is drawn and utilized as the reference scale to measure the distance in the digitized image after digitizing it with an image scanner

NOTE The transparency and thermal stability of the glass scale are convenient to get the digitized reference image with a transmitted image scanner and to make the contact image on the imaging plate.

3.12

goniometer stage

device to move the specimen laterally and vertically, and to tilt the specimen by tilting the specimen holder around the longitudinal holder axis

3.13

horizontal field width

HFW

original length corresponding to full width in the horizontal direction on a magnified image

3.14

image

two-dimensional projection of the specimen structure generated by TEM

NOTE A photographic film, an imaging plate, and an image sensor built into a digital camera are examples of devices for detecting the image.

3.15

image file format

processing method to encode the image information for storage in a computer file

3.16

image magnification

ratio of the linear dimension of the specific structure/scaling on the image detector, such as a photographic film, an imaging plate, or an image sensor built into a digital camera, to the corresponding linear dimension of the structure/scaling on the specimen

3.17

imaging plate

IP

electron image detector consisting of a film with a thin active layer embedded with specifically designed phosphors

3.18

image scanner

device that converts an analogue image into a digitized image with the desired resolution

NOTE There are mainly two different types of scanners: flatbed type and drum type.

3.19

image sensor

device, such as a charge-coupled device (CCD) array or complementary metal-oxide semiconductor (CMOS) sensor, that converts visual image information to an electric signal, built-in digital camera or other imaging devices

3.20

image wobbler

deflection coil to change direction of incident electron beam onto the specimen

NOTE This coil is activated in a periodic manner with the aim of identifying easily the place of focus.

3.21

just focus

focusing condition in which the specimen height coincides with the object plane of the objective lens

3.22

lattice image

image consisting of interference fringes formed by the interaction between the transmitted electron beam and diffracted electron beam from a specific crystal plane

NOTE Lattice fringes can be used to calibrate image magnification at the high end of the magnification range.

ISO 29301:2010(E)

3.23

lattice spacing

crystallographic distance between two adjacent parallel planes with the same Miller indices, which can be calculated from the value of the basic cell vector

3.24

magnetic hysteresis

physical phenomenon related to the magnetizing loop in which the magnetic field strength depends on the direction of the adjustment of the exciting current for the magnetic lens

3.25

optical axis

straight line passing through the symmetrical centre of the magnetic field of the electron lens

NOTE The path of an electron beam along this axis goes through the lens without changing the direction.

3.26

photographic film

negative film

sheet or a roll of thin plastic coated by photographic emulsion for recording an image

3.27

pixel-resolution

number of imaging pixels per unit distance of the detector

NOTE Typical unit is sometimes expressed as dots per inch (dpi).

3.28

reference material

RM

material or substance, one or more of whose property values are sufficiently homogeneous and well established to be used for the calibration of an apparatus, the assessment of a measurement method, or for assigning values to materials

NOTE For the purpose of this International Standard, an RM possesses periodic pattern(s) with the desired range of periodic interval and accuracy, to be used for the calibration of the image magnification.

3.29

region of Interest

ROI

a part region extracted from the whole area in the graph

3.30

specimen

small portion of a sample for observation

NOTE For TEM, a specimen has to be thin enough to transmit the electron beam.

3.31

specimen cartridge

part of specimen holder which supports a specimen and is attached to the tip of the specimen holder for use

3.32

specimen drift

unintentional movement of the specimen due to any source (thermal, mechanical, electric, charging)

3.33

specimen height

specimen position along the optical axis of the objective lens

NOTE 1 "Specimen height = 0" corresponds to the specimen position in correct focus under the standard excitation condition of the objective lens.

NOTE 2 See Reference [2] in the Bibliography.

3.34

specimen holder

device that supports a specimen in the right position in the pole-piece gap of the objective lens

3.35

standard excitation condition

optimal condition for excitation current of the objective lens to focus the image

NOTE 1 This condition is provided by the TEM manufacturer for each instrument.

NOTE 2 Image magnification is generally measured under this condition; however, as long as reproducible conditions are established, the magnification can be calibrated at any of the instrument settings.

3.36

super-lattice

stable periodic structure which is fabricated by alternating layers of at least two different kinds of materials

NOTE The super-lattice can be used as a reference material for calibration of image magnification from a medium-high to high magnification range.

3.37

transmission electron microscope

TEM

instrument that produces magnified images or diffraction patterns of the specimen by an electron beam which passes through the specimen and interacts with it

3.38

zone axis

crystallographic direction, designated $[uvw]$, defined by the intersection of a number of crystal planes $(h_1, k_1, l_1 \dots \dots h_i, k_i, l_i)$ such that all of the planes satisfy the so-called Weiss zone law; $hu + kv + lw = 0$

4 Image magnification

4.1 Definition of the image magnification

The image magnification (or scaling factor) of the TEM is defined by the ratio of the linear dimension of the specific structure on the detected image to the corresponding linear dimension of the specific structure in the specimen. There are three main kinds of image detectors: photographic film, imaging plate, and image sensor, such as CCD array or CMOS sensor built in the digital camera.

In general, the value of image magnification detected on an image sensor is different from the value of image magnification detected on the photographic film or imaging plate under the same electron optical conditions for TEM imaging, because the image-detecting positions are different from each other (see Figure 1).

ISO 29301:2010(E)

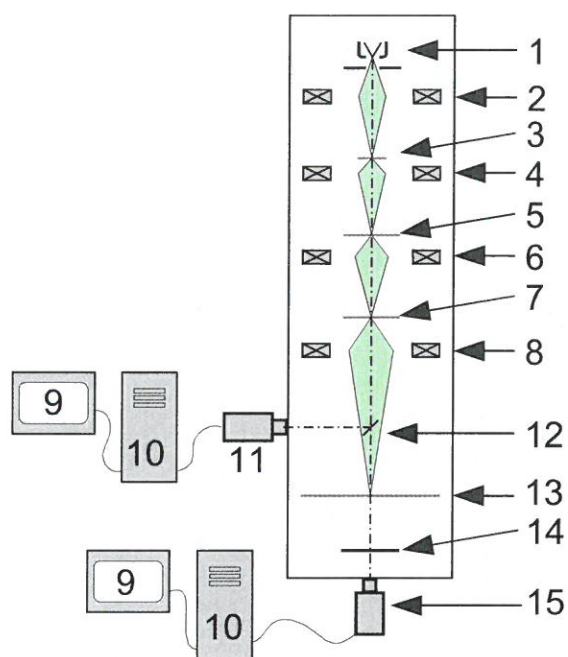

The digital camera (image sensor) position is different from the photographic film/imaging plate position.

Key

- | | |
|-----------------------|--|
| 1 electron gun | 9 monitor |
| 2 condenser lens | 10 computer |
| 3 specimen | 11 digital camera (image sensor) magnification; $M_s < M_g$ |
| 4 objective lens | 12 screen/mirror |
| 5 1st magnified image | 13 viewing screen |
| 6 intermediate lens | 14 photographic film/imaging plate magnification; M_f |
| 7 2nd magnified image | 15 digital camera (image sensor) magnification; $M_{is} > M_f$ |
| 8 projector lens | |

Figure 1 — Detector position in TEM system

4.2 Expressing magnification

The magnification of an image recorded on the photographic film or the imaging plate, or detected by the image sensor, is given by a number representing the number of times, and the number is accompanied by the symbol “x” (e.g. 10 000x, 10kx, 1 000 000x, 1Mx or ×10 000, ×10k, ×1 000 000, ×1M, where 10 000, 10k, 1 000 000 and 1M are magnitude numbers). Alternatively, introducing a scale bar having a length corresponding to unit length on the specimen can be used to represent the magnification. The digitized image should also indicate a magnification by detailing the number of pixels per unit distance of the raw data file.

NOTE The horizontal field width (HFW) is another way to define the scaling on a magnified image.

5 Reference materials

5.1 General

For calibrating the magnification of an image, wherever possible, choose a CRM that is produced in accordance with ISO Guide 34 and certified in accordance with ISO Guide 35.

When a suitable CRM is not available, an RM produced in accordance with ISO Guide 34 may be used.

5.2 Requirements for CRM/RM

Ensure that the chosen CRM/RM

- is stable with respect to vacuum and repeated electron-beam exposure,
- is aligned to a low-index zone axis along the electron optical axis, if the specimen region is a single crystal,
- provides a good contrast and clear interface for the periodic structure in the TEM image,
- can be cleaned to remove contamination without causing mechanical/electrical damage or distortion,
- has a smooth surface on both sides and identical thickness for a super-lattice structure, at least within the area used for the calibration process,
- has an associated valid calibration certificate.

NOTE Single crystal specimens of pure elements used for calibration do not need a calibration reference certificate.

5.3 Storage and handling

The CRM/RM shall be stored in a desiccating cabinet or in a vacuum container.

To ensure minimal handling of the actual CRM/RM, it may be permanently mounted on a specimen holder or a specimen cartridge.

The CRM/RM should be carefully handled without causing damage during the handling.

Check the contamination and deterioration of the CRM/RM, as these may affect calibration. Do not use the CRM/RM if it is damaged or grossly contaminated.

Check the calibration of the CRM/RM at intervals by comparing its calibration values with those of other CRMs/RMs; record the results. The frequency of verification may depend on the nature and usage of the CRM/RM.

The CRM/RM shall be used for calibration purposes only.

6 Calibration procedures

6.1 General

Parameters that influence the magnification of a TEM may cause systematic errors. These are listed in Annex A.

A major factor that influences the reproducibility of the calibration is the magnetic hysteresis of the electro-magnetic lens. It is necessary to minimize its influence by adopting the procedure described below in the

ISO 29301:2010(E)

same sequence each time, especially related to the direction of magnification setting (higher to lower, or lower to higher). Also, the specimen height and focus setting will influence the reproducibility of the calibration.

To obtain the value of the uncertainty within the laboratory, it is necessary to repeat the calibration procedure periodically.

The selection of the CRM/RM depends on the magnification range being used and the accuracy required. For the purpose of this International Standard, ensure that the uncertainty and repeatability of calibration is better than $\pm 5\%$ and 98 %, respectively.

The flowchart of the calibration procedure is shown in Annex B.

6.2 Mounting CRM/RM

At the time of mounting the specimen, ensure that handling of the CRM/RM is carried out in accordance with 5.3.

Mount the CRM/RM in accordance with the instructions provided by the TEM and the CRM/RM manufacturers.

Check that the CRM/RM is securely fixed on the specimen holder or specimen cartridge so that it does not move from its mounting. This enables any image degradation caused by vibration to be minimized.

Check that the height of the specimen in the specimen holder is at the position recommended by the TEM manufacturer's instructions, in order to keep the eucentric condition.

It is desirable to use a double-tilt or tilt-rotate specimen holder for aligning the crystal orientation of the specimen to the optical axis.

6.3 Setting TEM operating conditions for calibration

Set the operating condition of the TEM according to the following procedures to ensure, as far as possible, use of the same conditions.

- a) Check that the degree of vacuum in the TEM column is lower than 10^{-4} Pa and stable.
- b) The high voltage shall be applied and an appropriate time be allowed for it to stabilize.

NOTE Oil-filled 100 kV tanks take about 2,5 h; gas-filled tanks take about 45 min. Higher voltage instruments are normally operated with the high voltage continually applied, therefore a stabilization period is not usually required.

- c) Use an anti-contamination device, if needed.
- d) Select a specimen region of interest (ROI) for the calibration which is clean and free from damage, ensure the eucentric height of the ROI and adjust the height of the ROI, if necessary.
- e) In order to minimize the effect of the magnetic hysteresis of the lenses, set the magnification of the TEM to the target value for calibration according to the same sequence, for example, adjust higher magnification than the target magnification at first, then set the target magnification after that.
- f) Set the excitation of the objective lens to the desired reproducible value; the standard condition is recommended.
- g) Adjust the specimen height to focus the magnified image projected on the fluorescent screen, the TV monitor or the personal computer (PC) screen.

NOTE If the TEM in question is not equipped with a specimen-height control function, this procedure can be omitted.

ISO 29301:2010(E)

- h) Correct astigmatism at a slightly higher magnification than the target value and adjust the accelerating voltage centre. For example, if the target calibration is $\times 100k$, set the magnification in the range $\times 150k \sim \times 200k$ for alignment.
- i) Switch the observation mode of the TEM to the selected-area electron-diffraction (SAED) mode or the convergent-beam electron-diffraction (CBED) mode from the image mode. Also, make sure that the objective aperture is removed.

NOTE For the SAED mode, it is necessary to insert a selected-area aperture over the area of interest of the specimen in order to project a selected-area electron-diffraction pattern on the viewing device (fluorescent screen/TV monitor/PC screen).

- j) Adjust the condenser lens system to provide nearly parallel illumination conditions.
- k) Align a low-index zone axis of the crystal parallel to the optical axis (i.e. zone-axis illumination), if the specimen is a single crystal, see Figure 2.

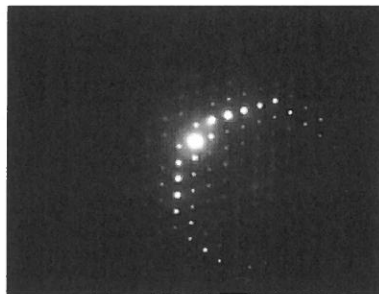

a) Off-axis condition

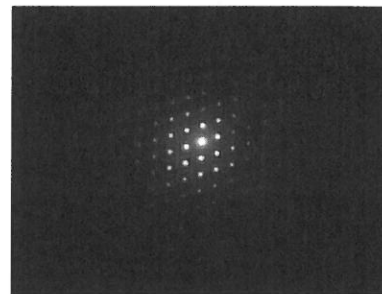

b) Zone-axis condition

Figure 2 — Difference of diffraction pattern by crystal orientation

- l) Insert the objective aperture, centring it about the electron optical axis. Also, switch the observation mode of the TEM back to the image mode.
- m) Return the magnification to the target value of calibration, and set the excitation current of the objective lens to the standard exciting condition again.
- n) Apply a relaxation function to relax the magnetic hysteresis of the objective lens, if the TEM has it.
- o) Adjust the specimen height to focus the magnified image roughly.

NOTE If the TEM in question is not equipped with a specimen-height control function, this procedure can be omitted.

- p) Adjust the fine focus by varying the exciting current of the objective lens.

NOTE If necessary, it is possible to use the Image Wobbler function for focusing the image.

- q) Turn off the auto-focus correction function to the optimum under-focus condition linked with the Image Wobbler function, if the TEM is equipped with this function.
- r) Adjust the illumination condition of the condenser lens system (spot size and brightness) with reference to the dynamic range of each detector to obtain image contrast in the whole dynamic range.

ISO 29301:2010(E)

The condenser lens system should be operated under conditions which approach parallel illumination. Alternatively, they should be done under a condition where it is documented that the beam convergence no longer affects the image focus. This can be done by recording multiple images under varying degrees of beam convergence.

6.4 Capturing digitized image

It is necessary to digitize the image in order to minimize readout error on the measurement of magnification. The bit depth of digitization of the image shall be larger than 8 bits. There are three ways of digitizing the magnified image corresponding to each image detector (refer to Table 1).

Table 1 — Comparison table for image detector

Image detection	Apparatus for digitization	Pixel size
Photographic film	Flatbed image scanner	Determined by resolution applied to image scanner
Imaging plate	Dedicated image digitizer	Determined by laser-beam diameter for readout
Image sensor (digital camera)	—	Same size as that of the image sensor

- a) Photographic film: the magnified image (for calibration) is directly exposed on it. The analogue image recorded on the photographic negative film shall be converted to a digitized image by using an image scanner, according to the procedure described in 6.5.

NOTE 1 It is preferable to use a flatbed image scanner, because it is easy to set the glass scale in it for pixel size calibration.

- b) Imaging plate (IP): the magnified image (for calibration) is directly exposed on it. The recorded image shall be obtained with a dedicated image digitizer (IP reader) which in turn is connected to a PC.

- c) Image sensor: the image (for calibration), captured by the image sensor (built into a digital camera and connected to a PC), is digitized and displayed on the monitor screen of the PC system. The image shall be saved on the memory in the PC system as an image file with a reversible format.

NOTE 2 Ensure that the procedure for normalization of gain is performed to get the uniform background of the digital camera image.

Before and during the execution of the digitization procedure, ensure the following conditions.

- The correct sensitivity setting is used for the photographic film used to get the negative image with proper density and contrast on the film.
- The exposure time is short so that blurring of the image due to drift is minimized in the recorded image.
- The readout process of the magnified image detected by the digital camera does not use "binning" treatment.
- Uncompressed file format, such as ESP, PICT, TIFF, or Windows bitmap, or a reversible (lossless) compressed file format, such as GIF or PING, shall be used for saving the digitized image.
- Ethical digital imaging requires that the original uncompressed image file be stored on archival media (e.g., CD-R) without any image manipulation or processing operation. All parameters of the production and acquisition of this file, as well as any subsequent processing steps, shall be documented and reported to ensure reproducibility. This is a quote from the MSA (Microscopy Society of America) Policy on Digital Imaging.

NOTE 3 Generally, acceptable (non-reportable) imaging operations include gamma correction, histogram stretching, and brightness and contrast adjustments. All other operations (such as unsharp-masking, Gaussian blur, etc.) shall be directly identified by the author as part of the experimental methodology. However, for diffraction data or any other image data that is used for subsequent quantification, all imaging operations shall be reported.

6.5 Digitizing the image recorded on photographic film

6.5.1 General

The flatbed image scanner with a transparent manuscript unit can be used to convert the analogue image recorded on the photographic negative film to a digitized image.

NOTE 1 Adjust the direction of the periodic structure in the image on the negative film along the Y-axis of the PC display, within a few degrees.

NOTE 2 In order to minimize the edge-distortion effects of the image scanner, set the negative film near the centre of the scan area.

6.5.2 How to decide the resolution for digitization

Generally, when the length L is measured with the dispersion (measurement deviation) dL , the minimum scale unit of the measurement shall be less than 1/10 of dL . This relation shall apply when considering the pixel size setting at the digitization of the recorded image on the photographic negative film by an image scanner.

Figure 3 shows the image of the specimen (CRM/RM) schematically in the plane of the image detector/display (negative film, IP, PC display, etc.). Note that the periodicity of the specimen is approximately aligned to the Y axis. θ is the angle between the Y axis and the axis (longitudinal direction) of the specimen. As seen in Figure 3, the target length (i.e. the actual transverse length of the specimen) L_t , in millimetres (mm), is calculated from the value of θ and the length L_e , in millimetres (mm), is extracted in the parallel direction to the X axis, using the formula $L_t = L_e \times \cos \theta$.

Also, $L_{e(\min)}$ is the minimum extracted length from the whole series of recorded images and U , in percent (%), is the dispersion obtained for the images of the CRM/RM. The pixel size or the scale unit S can then be set so that the condition set in Expression (1) is satisfied. Note that all the recorded images shall be digitized with the same value of S .

$$S \leq \left(L_{e(\min)} \times \frac{U}{100} \right) \times \frac{1}{10} \quad (1)$$

The resolution R_s (dpi) of the flatbed image scanner corresponding to the scale unit S , in millimetres (mm), is calculated using the following equation.

$$R_s = \frac{25,4}{S} = \frac{25\,400}{L_{e(\min)} \times U} \quad (2)$$

If S is smaller than 0,025 4 mm, set the resolution R_s (dpi) to be greater than or equal to the calculated value from Equation (2).

However, if S is larger than 0,025 4 mm, the calculated R_s will be smaller than 1 000 dpi. Such a low value of the resolution is unsuitable for making the appropriate measurement. In such a case, set the resolution to 1 000 dpi or more.

EXAMPLE 1 If the minimum length $L_{e(\min)}$ and the dispersion U are 5 mm and 2 % respectively, the calculated value of $S \leq 0,01$ mm. This corresponds to the resolution $R_s \geq 2\,540$ dpi.

EXAMPLE 2 If the minimum length of $L_{e(\min)}$ and the uncertainty U are 20 mm and 2 % respectively, the calculated S and R_s values are 0,04 mm and 635 dpi, respectively. This value of resolution is too poor to analyse the digitized image. In this case, set the resolution $\geq 1\,000$ dpi.

ISO 29301:2010(E)

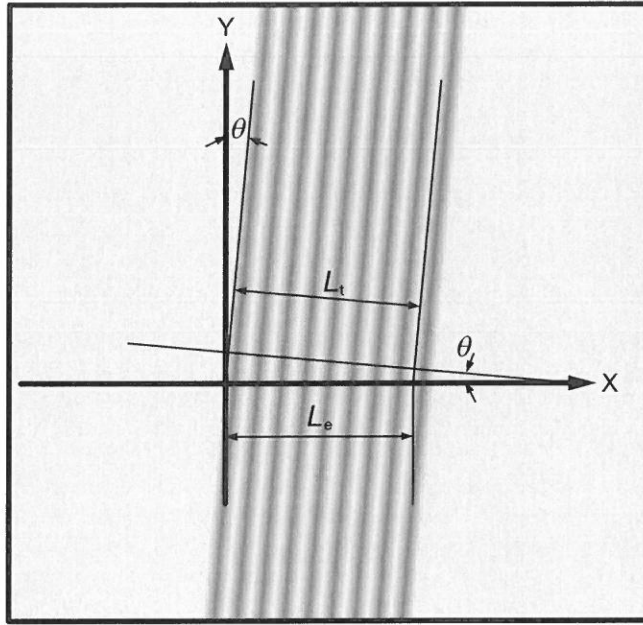

Figure 3 — Schematic image of periodic pattern with a layered structure

6.6 Measurement of the angle-corrected distance D_t from the digitized image

6.6.1 General

To avoid artefacts in identifying the edges of the features to be measured, the analyst should define the start and end points (edges) for measuring the angle-corrected distance D_t (refer to Figure 5) in the digitized image corresponding to the target length L_t (refer to Figure 3). Automated computer identification of edges should be used to assist in the detection of L_t .

The measurement software should provide the following basic functions:

- angle measurement;
- length measurement of the pixel unit;
- averaged line-profile function for arbitrary number of lines;
- ROI function on the averaged line profile;
- edge-detection function for the data in ROI, such as differential processing and maximum/minimum peak detection.

Do not use a photocopy, or similar, of the digitized image to avoid introduction of an artificial error.

NOTE It is important to enable someone else to check this procedure with the same software.

6.6.2 Measurement procedure

Get the angle-corrected distance D_t , in pixels, in the display plane of the image (PC display) using the following procedures, and record the measured values in the data sheet.

- a) Measure and record the tilt angle θ , in degrees, between the longitudinal direction of the periodic structure in the digitized image and Y-axis of the PC display (see Figure 4).

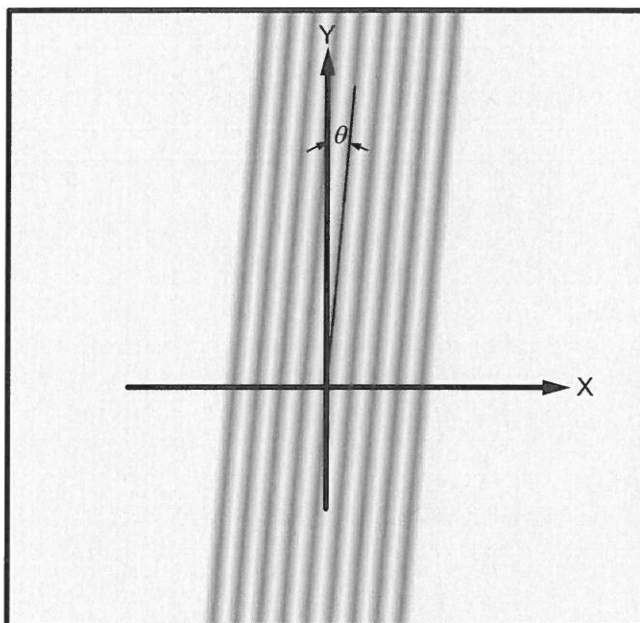

Figure 4 — Tilt angle θ

- b) Extract the basic pitch distance D_e , in pixels, from an arbitrary line LA parallel to the X-axis of the PC display (see Figure 5).

NOTE 1 Measure the basic pitch distance D_e as the centre-to-centre; alternatively, the analyst can measure either the left edge-to-left edge or the right edge-to-right edge distance from the periodic structures of the SRM/RM.

— Use the pixel value as the measurement unit.

— To reduce the influence of image noise in the line profile along a line LA and to improve the signal-to-noise ratio, apply an averaging processing along the periodic structure (not along the Y-axis) for n lines (see Figure 6).

NOTE 2 A procedure for choosing n (the number of lines for averaging) is described in Annex C.

ISO 29301:2010(E)

Points P_1 and P_2 correspond to both ends of distance D_e .

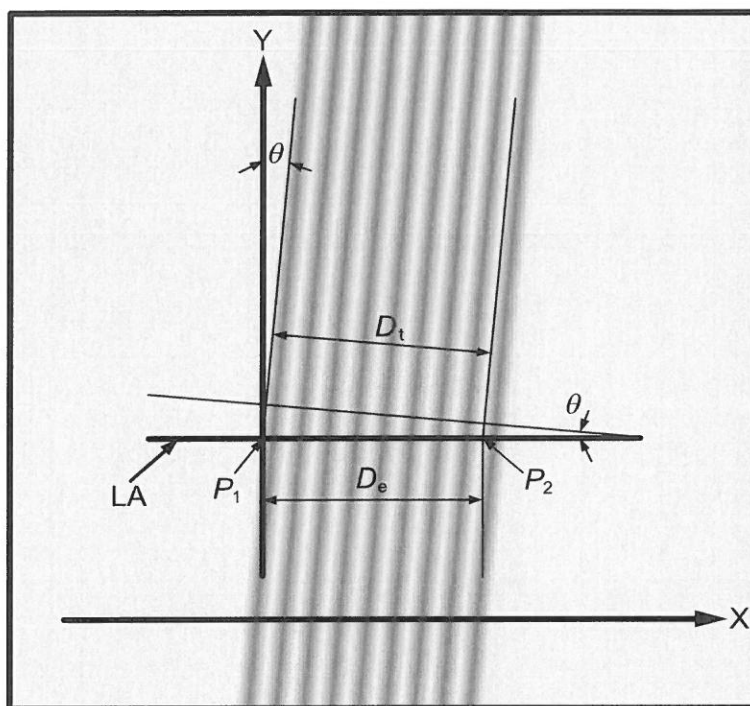
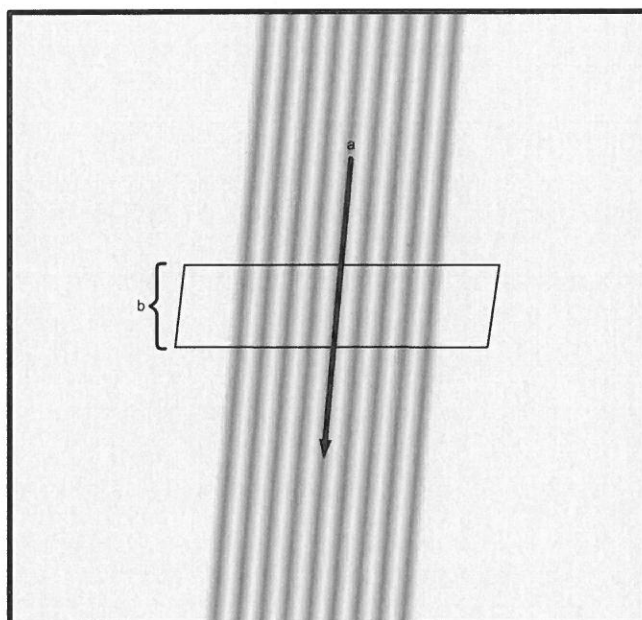

Figure 5 — Relationship between D_t , D_e and LA



- a Averaging.
- b n lines.

Figure 6 — Scheme of averaging for n lines along the direction of the periodic structure

ISO 29301:2010(E)

- c) Detect and record the pixel positions of both ends (P_1 , P_2) of the basic pitch distance D_e , in pixels, on the arbitrary line LA, by using a measurement software program applied for the averaged line profile.
- d) Calculate and record the basic pitch distance:

$$D_e = |P_1 - P_2| \quad (3)$$

NOTE Measure the basic pitch distance D_e either as the centre-to-centre or the edge-to-edge distance from the periodic structures of the CRM/RM.

- e) Calculate and record the angle-corrected distance D_t , in pixels, (see Figure 5) corresponding to the target length L_t for the magnification calibration by the following equation.

$$D_t = D_e \times \cos \theta \quad (4)$$

where

D_e is the extracted basic pitch distance represented by pixel units on the digitized image (see Figure 5);

θ is the measured tilt angle between the direction along the periodic structure and Y-axis of the PC display (see Figure 5).

Repeat the measurement at least three times at separate locations at least $(p + 10)$ pixels apart on the digitized image: where p is the number of lines applied to the averaging to get the smooth line profile.

6.7 Digitization of reference scale for pixel size calibration

To get a real dimension in SI units from the digitized length, it is necessary to calibrate the pixel size S , in millimetres (mm), applied to the image digitization.

When a photographic film a) or imaging plate b) is used as the image detector, it is necessary to calibrate the pixel size by using the digitized reference scale in the same manner as that used for digitization of the image. On the other hand, when the image sensor c) is used as the image detector, the value for the individual image sensor size, as guaranteed by the manufacturer, can be applied to the pixel size of the digitized image.

- a) Photographic film: a traceable calibrated ruler of a known accuracy and capable of measuring about 5 mm to 10 mm shall be used as a reference scale. Digitize the reference scale with the same flatbed image scanner under the same condition of resolution as used for the image digitization of photographic negative film. The direction of the reference scale shall be adjusted along the X-axis of the PC display, within a few degrees tilt (see Figure 7).

NOTE Typical reference glass scales are listed in Annex D.

ISO 29301:2010(E)

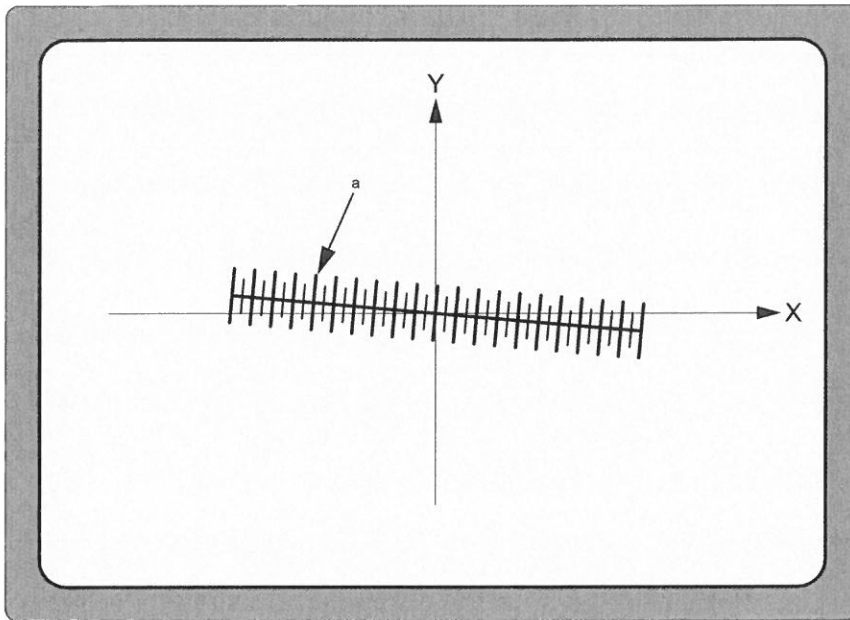

^a Reference scale.

Figure 7 — Arrangement of reference scale displayed on the PC monitor

- b) Imaging plate (IP): to get a contact image of a reference scale on the IP, place a traceable calibrated ruler of a known accuracy, capable of measuring around 50 mm to 100 mm, in contact, and shine a fluorescent lamp to obtain a contact image. Scan this image with the same dedicated digitizer (IP reader) under the same laser beam condition as that used for the image read-out. The direction of the reference scale shall be adjusted along the narrow side or another side of the imaging plate, within a few degrees tilt.
- c) Image sensor: as mentioned in 6.4, because the image sensor is built into the digital camera attached to the TEM column, it is very difficult to calibrate the pixel size by using the reference scale or other materials. Therefore, the size of the individual image sensor written in the specification guaranteed by the manufacturer can be applied as the pixel size of the digitized image.

6.8 Calibration of image magnification

6.8.1 General

The target length L_t , in millimetres (mm), on the detector plane can be obtained by multiplying the angle-corrected distance D_t , in pixels, measured on the digitized image and the calibrated scale unit (= pixel size) S , in millimetres (mm). Then, the image magnification M can be calculated by dividing the target length L_t , in millimetres (mm), by the original length L_o , in millimetres (mm), on the specimen corresponding to L_t .

6.8.2 Calibration of scale unit (= pixel size) S

When using a photographic film or an imaging plate, the pixel size of the digitized reference scale shall be calibrated to calculate the real dimension of the digitized distance.

Measure and record the number of pixels N , along the X-axis of the PC display, corresponding to the arbitrary readout length W_a , in millimetres (mm), and determine α . Use Equation 5 and Figure 8 to calculate W .

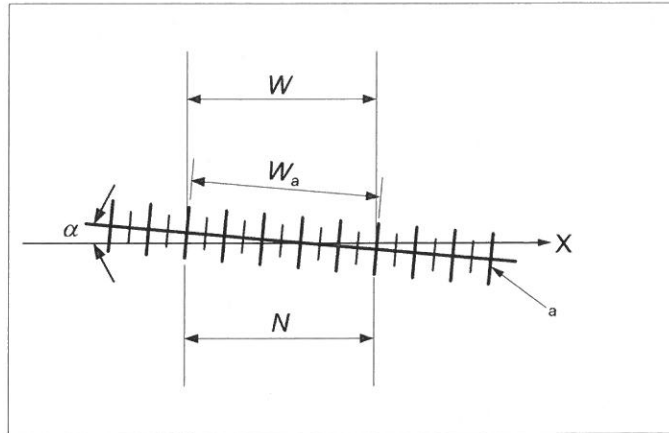

^a Scale axis.

Figure 8 — Reference scale inclined with tilt angle of α to the X-axis of the PC display

NOTE 1 W_a , in millimetres (mm), is the observed value from the digitized reference scale, not the measured value obtained by using other scales applied to the PC display.

$$W = W_a \times \cos \alpha \quad (5)$$

where α is the tilt angle between the scale axis and the X-axis of the PC display.

Then, the pixel size S , in millimetres (mm), can be calibrated by the following equation. Record the calculated values in the data sheet.

$$S = \frac{W}{N} = \frac{W_a \times \cos \alpha}{N} \quad (6)$$

NOTE 2 When the digital camera is used for this calibration procedure, the individual image sensor size defined in the specification, guaranteed by the manufacturer, can be used as the pixel size S . Record the guaranteed values on the data sheet.

6.8.3 Calculating image magnification

Determine the image magnification M , on the image detector plane using the following equation:

$$M = \frac{L_t}{L_o} = \frac{D_t \times S}{L_o} \quad (7)$$

where

L_t is the target length, in millimetres (mm), on the detector plane, as photographic film, imaging plate or image sensor;

L_o is the original length, in millimetres (mm), on the specimen plane, corresponding to the target length L_t ;

D_t is the angle-corrected distance, in pixels, on the digitized image, corresponding to the target length L_t ;

S is the scale unit (= pixel size), in millimetres (mm), of the digitized image.

ISO 29301:2010(E)

When photographic film or an imaging plate is used, Equation (7) can be expanded as follows:

$$M = \left(\frac{D_t \times W_a \times \cos \alpha}{N} \right) / L_o \quad (8)$$

where

- W_a is the arbitrary length (directly observed value), in millimetres (mm), on the digitized reference scale;
- α is the tilt angle, in degrees, between the scale axis and the X-axis of the PC display.
- N is the number of pixels, along the X-axis of the display, corresponding to the length W , in millimetres (mm), which is the projection on the X-axis of the arbitrary length W_a , in millimetres (mm).

6.9 Calibration of scale bar

6.9.1 General

The scale bar is useful to measure the particle size, the line width, and the distance in the structure, on the magnified image. The length of scale bar can be calculated according to calibrated magnification M and calibrated pixel size S , in millimetres (mm).

6.9.2 Basic scale size corresponding to one pixel on the digitized image

The calibrated pixel size S , in millimetres (mm), can be transferred to the basic scale size S_b , in millimetres (mm), corresponding to its length on the specimen plane, by dividing with the calibrated magnification M , as follows:

$$S_b = \frac{S}{M} \quad (9)$$

6.9.3 Calibration of scale bar

The number of pixels N_u and the displayed length L_u , in millimetres (mm), of the scale bar corresponding to the unit length (1 mm) on the specimen plane can be calculated by the following equations.

$$N_u = \frac{1}{S_b} = \frac{M}{S} \quad (10)$$

$$L_u = N_u \times S = M \quad (11)$$

These results can be extended to the different scale units, expressed in micrometres (μm) and nanometres (nm).

For the unit length of 1 nm, the number of pixels $N_{u(\text{nm})}$ and the displayed length $L_{u(\text{nm})}$, in millimetres (mm), of the scale bar are described as follows.

$$N_{u(\mu\text{m})} = \frac{1}{10^3} \left(\frac{M}{S} \right) \quad (12)$$

$$L_{u(\mu\text{m})} = \frac{M}{10^3} \quad (13)$$

ISO 29301:2010(E)

Also, for the unit length of 1 nm, the number of pixels $N_{u(\mu\text{m})}$ and the displayed length $L_{u(\mu\text{m})}$, in millimetres (mm), of the scale bar are described as follows.

$$N_{u(\text{nm})} = \frac{1}{10^6} \left(\frac{M}{S} \right) \quad (14)$$

$$L_{u(\text{nm})} = \frac{M}{10^6} \quad (15)$$

6.10 Calibration procedure for length measurements using photographic film only

Uncertainties of image digitizing and pixel calibration can be avoided by measuring the target length L_t directly on the film negative. In this case only the uncertainty of the glass scale has to be taken into account. For this measurement, however, it is important to minimize the measurement error.

7 Accuracy of image magnification

The accuracy means the closeness of agreement between a test result and the accepted reference value. (ISO 5725-1:1994, 3.6)

NOTE 1 A "test result" is the calibrated magnification obtained by the procedure outlined in this International Standard.

NOTE 2 The term "accepted reference value" is the magnification given by the TEM manufacturer.

The accuracy A , in percent, of the given magnification M_g can be determined by calculating the difference ΔM , using the following equation:

$$\Delta M = M_g - M \quad (16)$$

$$A = \left(\frac{M_g - M}{M} \right) \times 100 = \left(\frac{\Delta M}{M} \right) \times 100 \quad (17)$$

where

M is the calibrated image magnification;

M_g is the given magnification indicated on the TEM display.

NOTE 3 It is noted that the uncertainty due to operating conditions of the TEM apparatus, etc. and statistical errors due to any unavoidable inhomogeneity of the CRM/RM, etc. are included in the result of the magnification calibration. (See Annex A.)

ISO 29301:2010(E)

8 Uncertainty of measurement result

There are a lot of factors that influence the measurement results for the magnification calibration. These are listed in Annex A. Although the entire uncertainty of the measurement result may be calculated by considering the individual uncertainties, it is very difficult to measure each individual uncertainty corresponding to each of the factors independently.

In this International Standard, the entire uncertainty shall be treated by the following seven factors:

σ_{rm} Uncertainty of the reference materials (RM) for magnification,

σ_g Uncertainty of the reference glass scale,

σ_{IS} Uncertainty of the image sensor size of the digital camera,

σ_{De} Uncertainty of the basic pitch distance D_e ,

σ_θ Uncertainty of the tilt angle θ at image digitization,

σ_N Uncertainty of the pixel number N ,

σ_α Uncertainty of the tilt angle α at scale digitization.

According to the GUM, these uncertainties are classified into two categories; Type A uncertainties (U_A) include σ_{De} , σ_θ , σ_N , and σ_α and Type B uncertainties (U_B) include σ_{rm} , σ_g and σ_{IS} . The value of each factor included in the U_B shall be obtained from (C)RM certificate and/or technical documentation provided by the manufacturer.

The uncertainties σ_{De} , σ_θ , σ_N and σ_α shall be calculated from the results by m and n replicate measurements, respectively. To do this, the procedures from 6.2 to 6.6, shall be repeated m times to get the σ_{De} and σ_θ , and similarly the procedures from 6.7 to 6.8.2 shall be repeated n times to get the σ_N and σ_α (see Figure 9). The frequency of repetitions (namely m and n) shall be three times or more.

NOTE 1 If σ_{rm} , σ_g and σ_{IS} are not presented, each uncertainty σ can be calculated based on the procedure of uniform distribution treatment.

The standard deviation σ_e , of the calibrated magnification for m and n independent measurements can be calculated by Equation (18) or (19).

In the case of the photographic film or the imaging plate, use

$$\sigma_e = \sqrt{\left(\frac{\sigma_{De}}{\sqrt{m}}\right)^2 + \left(\frac{\sigma_\theta}{\sqrt{m}}\right)^2 + \left(\frac{\sigma_N}{\sqrt{n}}\right)^2 + \left(\frac{\sigma_\alpha}{\sqrt{n}}\right)^2 + \sigma_{rm}^2 + \sigma_g^2} \quad (18)$$

Also, in the case of the digital CCD camera, use

$$\sigma_e = \sqrt{\left(\frac{\sigma_{De}}{\sqrt{m}}\right)^2 + \left(\frac{\sigma_\theta}{\sqrt{m}}\right)^2 + \sigma_{rm}^2 + \sigma_{IS}^2} \quad (19)$$

The uncertainty σ , of the calibrated magnification for a series of measurements can be defined by the following equation.

$$\sigma = k \times \sigma_e \quad (20)$$

where k is the coverage factor.

NOTE 2 For a confidence limit of approximately 95 %, k is set to 2; and for a confidence limit of approximately 99 %, k is set to 3.

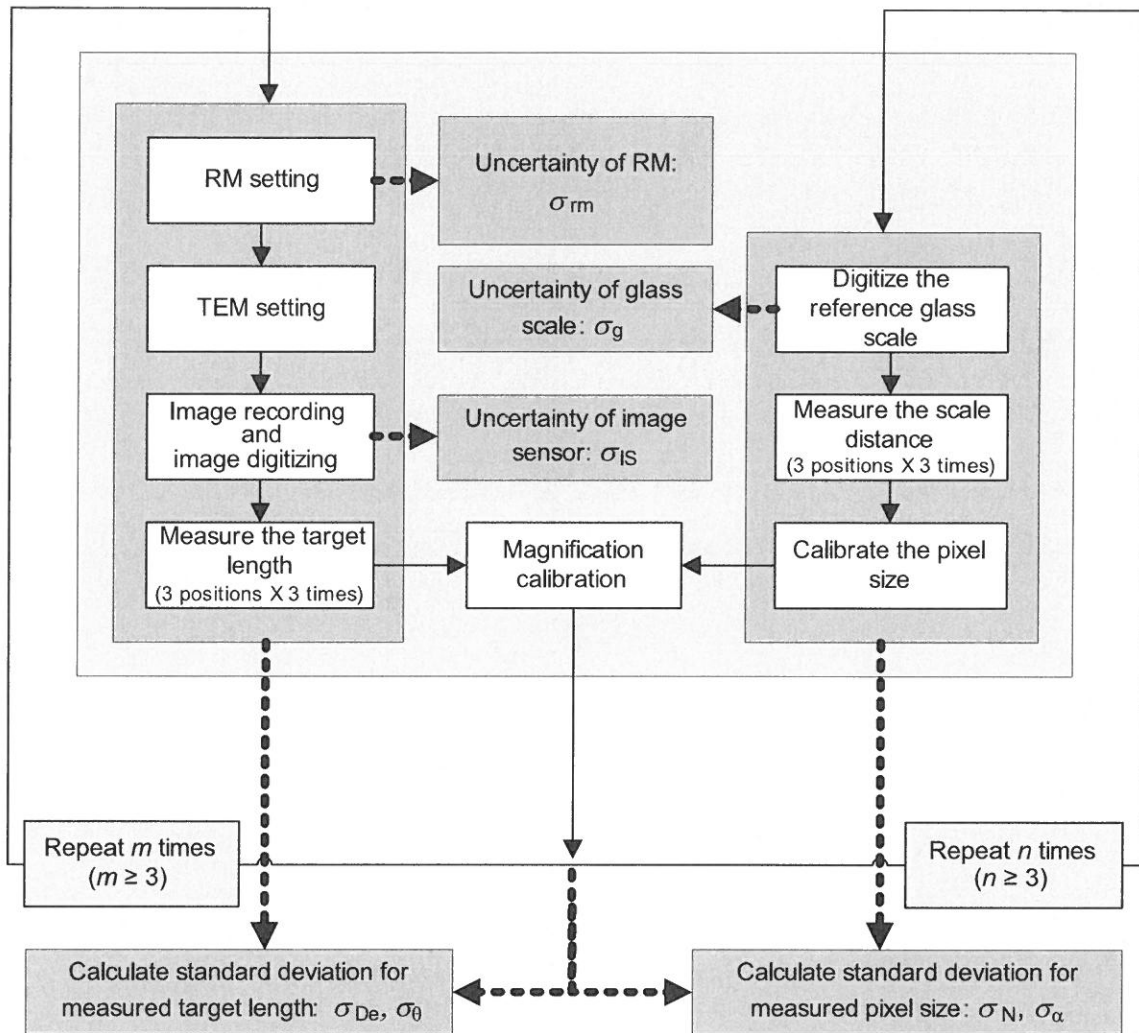

Figure 9 — Main five factors related to the uncertainty

9 Calibration report

9.1 General

The calibration report carried out by the laboratory shall be accurate, clear, unambiguous and in accordance with the specific instructions in the calibration procedures given in Clauses 6 to 8.

The results of the measurements shall be listed in a test report and, in addition to the information requested by the client, shall include all the information necessary for the interpretation of the calibration results and that required by ISO/IEC 17025:2005, 5.10.2.

In the case of calibrations performed for internal clients, or in the case of a written agreement with the client, the results may be reported in a simplified way. The information listed in 5.10.2 of ISO/IEC 17025:2005, which is not reported to the client, shall be readily available in the laboratory which carried out the calibrations.

ISO 29301:2010(E)

9.2 Contents of calibration report

In the calibration report, include the following and any other relevant information which could affect the results of the calibration. An example of a report is given in Annex E.

- a) title (e.g. "Test reports" or "Calibration certificates");
- b) name and address of the laboratory;
- c) reference number of the calibration report;
- d) name and address of the client, where relevant;
- e) identification of the method used (i.e. ISO 29301:2010);
- f) manufacture's name, model name and the serial number of the TEM used;
- g) name and identification of the reference materials used;
- h) specific operating values of the accelerating voltage, in kilovolts (kV);
- i) type of image formation mode used, LOW MAG mode, MAG mode, SAMAG mode, MAG Zoom mode;
- j) all lens currents for the magnification being calibrated;
- k) type of specimen holder used;
- l) procedure to set the target magnification for calibration;
- m) manufacturer's name, model name and the serial number of the digital camera used for detection of the image;
- n) specifications of image sensor built into the digital camera; number of pixels in X and Y direction, and pixel size of individual image sensor;
- o) manufacturer's name, model name and the serial number of the film scanner used for digitization of the image;
- p) name and identification of the glass scale used as the reference scale;
- q) name and identification of the application software used;
- r) number of measurements taken (n and m) and results of calibration: magnifications in both X and/or Y with the accuracy and uncertainty;
- s) name of the person conducting the calibration;
- t) date and time of the calibration;
- u) name(s), function(s) and signature(s) of person(s) authorizing the calibration certificate;
- v) where relevant, a statement to the effect that the results relate only to the items tested or calibrated.

For hard copies of test reports and calibration certificates, it is recommended that the page number, total number of pages and number of the calibration report are included.

It is recommended that laboratories include a statement specifying that the calibration report shall not be reproduced except in full, without written approval of the laboratory.

- w) if requested by the customer, the algorithm used for the application program shall be disclosed.

Annex A **(informative)**

Parameters that influence the resultant magnification of a TEM

The parameters listed below may interact with each other, and are considered in order of their location in the instrument.

A.1 Electron-gun high-voltage instability or drift can change the energy of the electrons, thereby changing the final focus which affects the magnification calibration.

A.2 Even if the target magnification for calibration is the same, a calibrated magnification may differ in each applied accelerating voltage (e.g. 100 kV, 200 kV, etc).

A.3 An uncorrected objective-lens astigmatism can give a false indication of the exact focus.

A.4 The electron-beam convergence can also affect the image focus, particularly at high magnifications. The condenser lens system should be operated under conditions which approach parallel illumination. Alternatively, they should be done under a condition where it is documented that the beam convergence no longer affects the image focus. This can be done by recording multiple images under varying degrees of beam convergence.

A.5 Residual magnetic hysteresis, particularly in the objective lens, can change the focal conditions.

A.6 The alteration and instabilities of the excitation current of the objective lens can change the focal conditions.

A.7 The alteration of the specimen height can change the focal conditions.

A.8 The zoom control of magnification can be nonlinear.

A.9 The percentage error in magnification may be different for each magnification range.

A.10 The alteration of the orientation of the (crystal) specimen to the optical axis will introduce magnification variation.

A.11 Thermal and electronic drift of circuit components related to the magnified lenses can affect magnification with time.

A.12 Expansion or contraction of photographic material, photographic enlarging, and digital printing can all have a significant effect on the final apparent image magnification.

A.13 In digitally recorded images, magnification errors may occur due to inaccuracies or distortion of the digital devices (e.g. image scanner, etc). The aspect ratio (X and Y magnification) may be different than that of the original image.

A.14 Determination of the position of edges of lines or periodic structures can affect the magnification resultant.

ISO 29301:2010(E)

Annex B
 (normative)

Flowchart of image-magnification calibration procedure

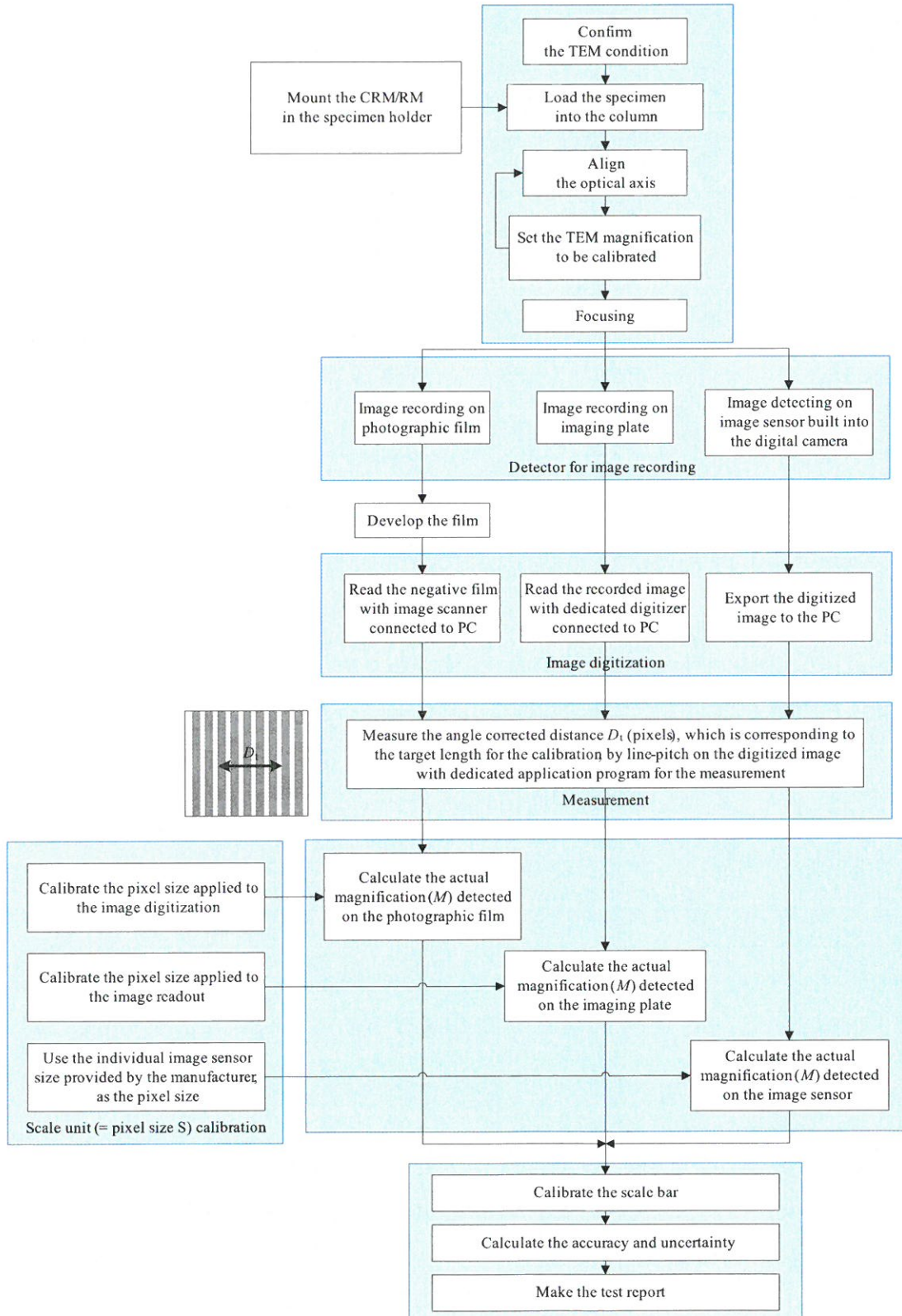

Annex C (normative)

How to decide the number of lines for averaging

C.1 Procedure to decide the number of lines to get the smooth line profile

In order to get a smooth line profile, the number of lines applied to the averaging process shall be determined by the following procedure.

- a) Generate the electron beam without setting the TEM sample.
- b) Adjust the illumination lens system to illuminate the fluorescent screen with the homogeneous electron beam, at around $\times 30k$.
- c) Expose the image (no specimen) with a proper electron dose according to the detector sensitivity.
- d) Convert the detected image to a digitized image (6.4).
- e) Get the line profile of "500 pixels (or more) $\times n$ line" along the X-axis on the PC screen.
- f) Set n to 1 – 500 lines (or more) by a suitable interval to get a smooth curve on the graph plotted in j), and calculate the standard deviation of the line profile for each setting of n .
- g) Repeat procedures e) and f), for three different positions in the digitized image.
- h) Get the averaged standard deviation for each n , from the calculated data for three different positions.
- i) Normalize the obtained standard deviation as it is applied to 1 at $n = 1$.
- j) Plot a graph of the normalized standard deviation (SD) versus the number of lines n .
- k) Get the number of lines n_0 so that the variable ratio of the standard deviation $[\Delta SD/\Delta n = (SD_i - SD_{i-1})/(n_i - n_{i-1})]$ becomes 0,001 or less.
- l) The number of lines n_a applied to the averaging processing is obtained by $(2 \times n_0)$.

ISO 29301:2010(E)

C.2 Example of experimental results

An example of experimental results is given in Table C.1 and Figure C.1.

Table C.1 — Experimental data for averaging the standard deviation

No. of lines	Averaged SD	Normalized SD	Variable ratio
1	101,640	1,000	
2	79,460	0,782	0,218 2
3	76,490	0,753	0,029 2
5	66,230	0,652	0,050 5
8	56,270	0,554	0,032 7
10	52,700	0,518	0,017 6
20	41,090	0,404	0,011 4
50	27,420	0,270	0,004 5
80	22,730	0,224	0,001 5
100	21,130	0,208	0,000 8
150	18,500	0,182	0,000 5
200	16,870	0,166	0,000 3
250	15,590	0,153	0,000 3
300	14,410	0,142	0,000 2
400	13,770	0,135	0,000 1
500	13,130	0,129	0,000 1
800	11,800	0,116	0,000 0
1 000	11,520	0,113	0,000 0

The variable ratio becomes lower than 0,001 when the number of lines is higher than 90.
 The necessary number of lines for averaging n_a is $2 \times n_0 = 2 \times 90 = 180$.

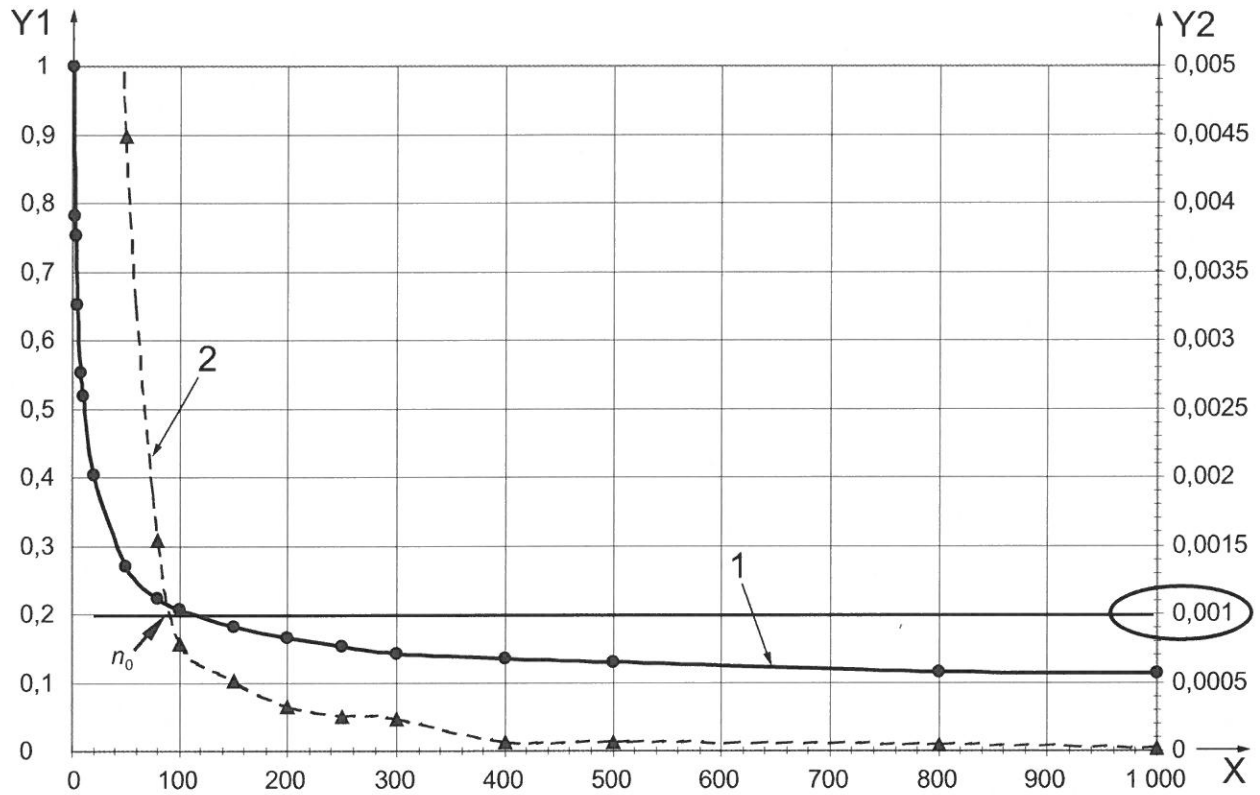

Key

- 1 number of lines vs. standard deviation
- 2 variable ratio
- X number of lines
- Y₁ normalized standard deviation (SD)
- Y₂ $\Delta SD / \Delta n$

Figure C.1 — SD and variable ratio vs number of lines

ISO 29301:2010(E)

Annex D (informative)

Reference materials for magnification calibration

The following information is given for the convenience of users of this International Standard and does not constitute an endorsement by ISO of these products

D.1 Reference materials (RMs) for calibration of magnification scale

Examples of CRMs and RMs available for calibration of magnification scales for the TEM apparatus are given in D.1.1 to D.1.3.

D.1.1 Bundesanstalt für Materialforschung und Prüfung, Germany

BAM-L002/XXX¹⁾: Nanoscale strip pattern for length calibration and test of lateral resolution; AlGaAs-InGaAs multilayer on the Si wafer; certified value; 74 nm, 145 nm, 288 nm, 478 nm and 964 nm.

NOTE This material is supplied in the form of a block of conducting epoxy with dimensions of about 12 mm × 10 mm × 4 mm. It is necessary to cut out the thin film from the block for TEM observation by the customer.

D.1.2 Norrox Scientific Ltd., Canada

MAG*I*CAL²⁾: SiGe/Si multilayer on Si <001> substrate; certified value; around 10 nm, 100 nm, 1 µm, 5 µm.

NOTE 1 This material is supplied in the form of thin foil on the TEM specimen grid which is suitable for TEM observation.

NOTE 2 Norrox Scientific Ltd. (manufacturer and supplier) distribute the MAG*I*CAL to many suppliers such as Agar Scientific Ltd., EMS (Electron Microscopy Sciences), SBT (South Bay Technology, Inc.), SPI (Structure Probe, Inc.), Ted Pella, Inc.

D.1.3 Analysing crystal for X-ray analysis

Analysing crystals consist of two kinds of materials [for example, tungsten (W) and silicon (Si)] alternately superimposed on Si substrate. The line pitch used for the magnification calibration shall be calibrated by using X-ray diffraction analysis. The line pitches of about 5 nm to 50 nm are recommended.

NOTE Other reference materials having different combinations with other materials as the multilayer can be used.

1) BAM-L002/XXX is an example of a suitable product available commercially. This information is given for the convenience of users of this document and does not constitute an endorsement by ISO of this product. Equivalent products may be used if they can be shown to lead to the same results.

2) MAG*I*CAL is the trade name of a product supplied by Norrox Scientific Ltd. This information is given for the convenience of users of this document and does not constitute an endorsement by ISO of the product named. Equivalent products may be used if they can be shown to lead to the same results.

D.2 Reference materials (RMs) for calibration of pixel size

Examples of RMs available for calibration of the pixel size of a digitized image are given below.

D.2.1 National Institute of Standards and Technology, USA

SRM2800 (NIST): Microscope Magnification Standard, distance range $\pm 1 \mu\text{m}$ to $\pm 5 \text{mm}$, chrome printed on a fused-quartz substrate.

D.2.2 Brown & Shape Precizika, USA

Minimum possible grating pitch $10 \mu\text{m}$, chrome deposited on a float-glass substrate.

D.2.3 GELLER Microanalytical Laboratory, USA

- a) Magnification Reference Standard (MRS)³⁾, square-box type, line pitches $2 \mu\text{m}$, $50 \mu\text{m}$ and $500 \mu\text{m}$, chromium patterned on a quartz substrate.
- b) A traceable Micro-Ruler⁴⁾ for light microscope image, overall scale 150mm with $0,01 \text{mm}$ increments, anti reflective chromium patterned on a soda-lime glass.

D.3 d-spacing of some pure elements

Table D.1 shows d-spacing of some pure elements suitable for magnification calibration.

Table D.1 — d-spacing of some pure elements suitable for magnification calibration

Element	Index	d-spacing nm
Gold (Au)	111	0,235
	200	0,204
	220	0,144
Silver (Si)	111	0,314
	200	0,272
	220	0,192

3) MRS is the trade name of a product supplied by GELLER Microanalytical Laboratory. This information is given for the convenience of users of this document and does not constitute an endorsement by ISO of the product named. Equivalent products may be used if they can be shown to lead to the same results.

4) The Micro-Ruler is the trade name of a product supplied by GELLER Microanalytical Laboratory. This information is given for the convenience of users of this document and does not constitute an endorsement by ISO of the product named. Equivalent products may be used if they can be shown to lead to the same results.

ISO 29301:2010(E)

D.4 Examples of the image having a periodic structure

Figure D.1 shows typical reference materials with periodic structure used for the magnification calibration in a specific magnification range.

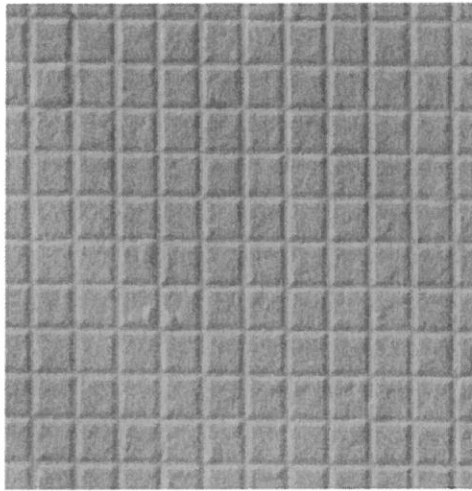

a) Grating replica (2 000 lines/mm)
for low-range magnification

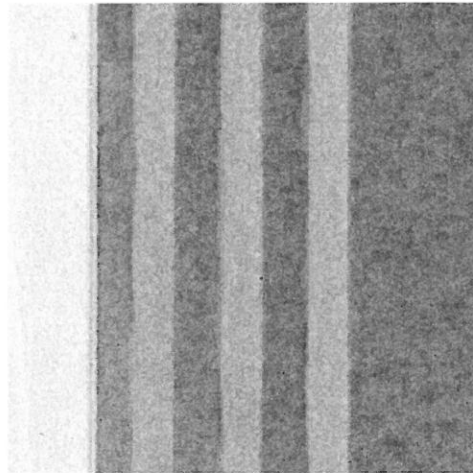

b) Super-lattice structure for middle range of
magnification; GaAs (9,5 nm)/AlAs (9,5 nm)

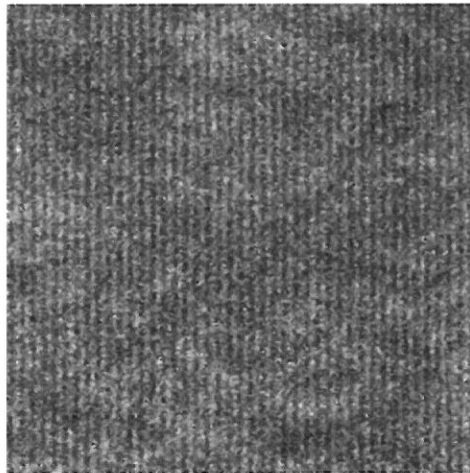

c) Crystal lattice image for high range of magnification; Au (200) 0,204 nm spacing

Figure D.1 — Typical reference materials for magnification calibration

Annex E (informative)

Example of test report for calibration of TEM magnification

This annex is an example of a “condition” matrix for tracking calibrated magnifications as part of a quality-control program.

Refer to the example in the test-report table below.

NOTE 1 Insert the actual magnification measured against the calibration standard.

NOTE 2 The above frequency of repetitions of independent measurements m and n , accelerating voltage, magnification mode, magnification, and image resolution of scanner are for example only. These values can be adjusted to represent those settings that are used in practice. A different number of settings to those given in this example may be used.

The result should be plotted as a control chart to show variability over time.

ISO 29301:2010(E)

Test Report for Calibration of TEM Magnification

Number of the calibration report: _____

Name of the testing laboratory: _____

Address of the testing laboratory: _____

International Standard reference: ISO 29301:2010

Name of the client: _____

Address of the client: _____

Name of the TEM manufacturer: _____

Address of the TEM manufacturer: _____

TEM Model: _____ (Serial number: _____)

Specimen holder model: _____ (Serial number: _____)

Name and identification of reference materials: _____

Operating voltage: _____ (kV)

Image formation mode: () LOW-MAG, () MAG, () SAMAG, () MAG zoom

Procedure to set the target magnification for calibration:

Name of the digital camera manufacturer: _____

Address of the digital camera manufacturer: _____

Specification of image sensor built into the digital camera

1. number of pixels in X and Y directions: _____ x _____

2. pixel size of individual image sensor: _____ x _____

Name of the film scanner manufacturer: _____

Address of the film scanner manufacturer: _____

ISO 29301:2010(E)

Name and identification of reference scale for digitized image: _____

Name and identification of application software: _____

Operator name: _____

Testing date: _____

Name of person(s) authorizing: _____

Signature of person(s) authorizing: _____

ISO 29301:2010(E)

DATA SHEET for D_t , σ_{rm} and σ_a

Frequency of repetitions of independent measurement: m = 3 times

Name of (C)RM: _____ $\sigma_{rm} =$ _____

Accelerating voltage: 200 kV

Tilt angle θ between the direction along periodic structure and the Y-axis of the PC display

Order of repetitions	θ (degrees)	Averaged θ	σ_θ
1			
2			
3			

Mode (check)	Magnification (M_g)	Order of repetition	Measurement				Averaged D_e	σ_{De}
			position	repeat	D_e (pix)	D_t (pix)		
<input type="checkbox"/> LOW MAG	×100K	1st of 3 times	1	1				
				2				
				3				
			2	1				
				2				
				3				
			3	1				
				2				
				3				
<input type="checkbox"/> MAG	×100K	2nd of 3 times	1	1				
				2				
				3				
			2	1				
				2				
				3				
			3	1				
				2				
				3				
<input type="checkbox"/> SAMAG	×100K	3rd of 3 times	1	1				
				2				
				3				
			2	1				
				2				
				3				
			3	1				
				2				
				3				
<input type="checkbox"/> MAG zoom	×100K	3rd of 3 times	1	1				
				2				
				3				
			2	1				
				2				
				3				
			3	1				
				2				
				3				
						$D_{t(AV)}$ =	Overall average of D_e $D_{e(AV)} =$	

ISO 29301:2010(E)

σ_{rm}	Uncertainty of (C)RM,
M_g	Given magnification indicated on TEM display,
D_e	Basic pitch distance (pix) in digitized image of magnified reference structure,
$D_t (= D_e \times \cos \theta)$	Angle-corrected pitch distance (pix) in digitized image of magnified reference structure,
σ_θ	Standard deviation calculated from a series of θ values.
σ_{De}	Standard deviation calculated from a series of averaged D_e values.

Remarks/Comments:

ISO 29301:2010(E)

DATA SHEET for S , σ_g and σ_b

(This table is needed only for photographic film or imaging plate use)

Frequency of repetitions of independent measurement: $m = 3$ times

Name of glass scale: _____ $\sigma_g =$ _____

Accelerating voltage: 200 kV

Tilt angle α between the scale axis and the X-axis of the PC display

Order of repetitions	α (degree)	Averaged α	σ_α
1			
2			
3			

Image resolution of scanner	Order of repetition	Measurement						Averaged N	σ_N
		position	repeat	W_a (mm)	N (pix)	W (mm)	$S = W/N$		
2400 dpi	1st of 3 times	1	1						
			2						
			3						
		2	1						
			2						
			3						
		3	1						
			2						
			3						
	2nd of 3 times	1	1						
			2						
			3						
		2	1						
			2						
			3						
		3	1						
			2						
			3						
	3rd of 3 times	1	1						
			2						
			3						
		2	1						
			2						
			3						
		3	1						
			2						
			3						
							$S_{(AV)} =$	Overall average of $N_{(AV)}$	
								$N_{(AV)} =$	

ISO 29301:2010(E)

- σ_g Uncertainty of glass scale,
- W_a Readout value of the arbitrary length in the digitized glass scale,
- $W (= W_a \times \cos \theta)$ Width along X-axis of PC display corresponding with W_a ,
- N Number of pixels included in W ,
- S Pixel size calculated from W and N ,
- σ_a Standard deviation calculated from a series of a values.
- σ_N Standard deviation calculated from a series of averaged N values.

Remarks/Comments:

ISO 29301:2010(E)

Calibration Results

(For photographic film or imaging plate use)

Magnification to be calibrated: M_g $M_g =$ _____

Calibrated magnification: $M = [D_{t(AV)} \times S_{(AV)}] / L_o$ $M =$ _____

Accuracy: $A = \{(M_g - M) / M\} \times 100$ $A =$ _____

Uncertainty: $\sigma =$ _____

$$\sigma = k \times \sigma_e = k \times \sqrt{\left(\frac{\sigma_{De}}{\sqrt{m}}\right)^2 + \left(\frac{\sigma_{\theta}}{\sqrt{m}}\right)^2 + \left(\frac{\sigma_N}{\sqrt{n}}\right)^2 + \left(\frac{\sigma_{\alpha}}{\sqrt{n}}\right)^2 + \sigma_{rm}^2 + \sigma_g^2}$$

Calibrated scale bar for 1 μm : $L_u(\mu\text{m}) = M / 10^3$ $L_u(\mu\text{m}) =$ _____ (mm)

Calibrated scale bar for 1 nm: $L_u(\text{nm}) = M / 10^6$ $L_u(\text{nm}) =$ _____ (mm)

M_g Given magnification indicated on TEM display,

$D_{t(AV)}$ Overall averaged value of the pitch distance (pix) in digitized image of magnified reference structure,

L_o Actual length of reference structure on (C)RM corresponding to $(D_t \times S)$,

$S_{(AV)}$ Overall averaged value of pixel size,

σ_e Entire standard deviation of calibrated magnification,

σ_{De} Standard deviation calculated from a series of averaged D_e values.

σ_{θ} Standard deviation calculated from a series of θ values.

σ_N Standard deviation calculated from a series of averaged N values.

σ_{α} Standard deviation calculated from a series of α values.

σ_{rm} Uncertainty of (C)RM,

σ_g Uncertainty of reference glass scale,

m Frequency of repetitions for independent measurement of pitch distance of (C)RM,

n Frequency of repetitions for independent measurement of pixel size at image digitization,

k Coverage factor; the confidence interval is about 95 % or 99 %, the factor k can be set to 2 or 3, respectively.

$L_{u(\mu\text{m})}$ Length of calibrated scale bar corresponding to 1 μm .

$L_{u(\text{nm})}$ Length of calibrated scale bar corresponding to 1 nm.

Calibration Results

(For digital camera use)

Magnification to be calibrated: M_g $M_g =$ _____
 Pixel size: S $S =$ _____ (mm)
 Calibrated magnification: $M = [D_{t(AV)} \times S_{(AV)}] / L_o$ $M =$ _____
 Accuracy: $A = \{(M_g - M) / M\} \times 100$ $A =$ _____
 Uncertainty: $\sigma =$ _____

$$\sigma = k \times \sigma_e = k \times \sqrt{\left(\frac{\sigma_{De}}{\sqrt{m}}\right)^2 + \left(\frac{\sigma_{\alpha}}{\sqrt{m}}\right)^2 + \sigma_{rm}^2 + \sigma_{IS}^2}$$

Calibrated scale bar for 1 μm : $L_u(\mu\text{m}) = M / 10^3$ $L_u(\mu\text{m}) =$ _____ (mm)
 Calibrated scale bar for 1 nm: $L_u(\text{nm}) = M / 10^6$ $L_u(\text{nm}) =$ _____ (mm)

- M_g Given magnification indicated on TEM display
- S Pixel size of image sensor guaranteed by manufacturer
- $D_{t(AV)}$ Overall averaged value of the pitch distance (pix) in digitized image of magnified reference structure,
- L_o Actual length of reference structure on (C)RM corresponding to $(D_t \times S)$,
- σ_e Entire standard deviation of calibrated magnification,
- σ_{De} Standard deviation calculated from a series of averaged D_e values.
- σ_{θ} Standard deviation calculated from a series of θ values.
- σ_{rm} Uncertainty of (C)RM,
- σ_{IS} Uncertainty of pixel size of image sensor,
- m Frequency of repetitions for independent measurement of pitch distance of (C)RM,
- k Coverage factor; the confidence interval is about 95 % or 99 %, the factor k can be set to 2 or 3, respectively.
- $L_u(\mu\text{m})$ Length of calibrated scale bar corresponding to 1 μm .
- $L_u(\text{nm})$ Length of calibrated scale bar corresponding to 1 nm.

ISO 29301:2010(E)

Bibliography

- [1] ISO 5725-1:1994, *Accuracy (trueness and precision) of measurement methods and results — Part 1: General principles and definitions*
- [2] JOHN, C.H. SPENCE, *Experimental high-resolution electron microscopy* (Second Edition), Oxford University Press, 1988
- [3] WILLIAMS, David B. and BARRY CARTER, C. *Transmission Electron Microscopy, Vol. 1 Basic*, Plenum Press, New York, 1996

ISO 29301:2010(E)

ICS 37.020

Price based on 40 pages